



A New Approach to Fastening Thin Sheet Metal Panels by Ken Gomes

For years assemblers of thin panels have focused on reducing stripped joints. The low expense of purchasing standard type A, B and AB screws is mitigated by the high incidence of "strippers". Many innovative fastener suppliers have tried to improve the stripping resistance of standard type A, AB and B sheet metal screws. Most of the efforts centered on improving the torque that came from the underhead bearing surface. Various undercuts and torque robbing nibs and serrations have been used with only a modest improvement.

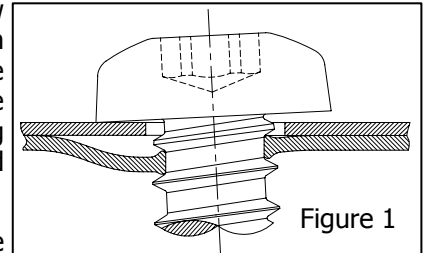

Figure 1

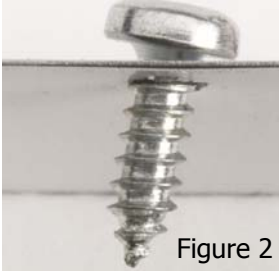

Figure 2

Unfortunately, these approaches do not address the limitations of spaced threads on standard sheet metal screws.

The current disadvantage of using standard sheet metal screws with spaced threads is that the sheet metal deflects due to the single lead thread, particularly when the nut material thickness is equal to or less than the thread pitch. This condition occurs more often as there is an on-going market trend to use thinner materials. Under these conditions, the sheet metal nut material is not really thread formed, but is deflected to conform to the screw helix into the root area of the screw. **See Fig. 1 & 2.**

This condition using standard sheet metal screws causes the screw to frequently be off axis causing the head to seat off axis. Since the underhead bearing surface does not seat flush on the laminate, stripping resistance is greatly reduced. Another contributing factor to stripping is the reduced thread diameter under the screw head typical in standard sheet metal screws.

To avoid the aforementioned inherent limitations of standard sheet metal screws, REMINC has developed the new FASTITE® 2000™ line of TRILOBULAR™ fasteners. **See Fig. 3.**

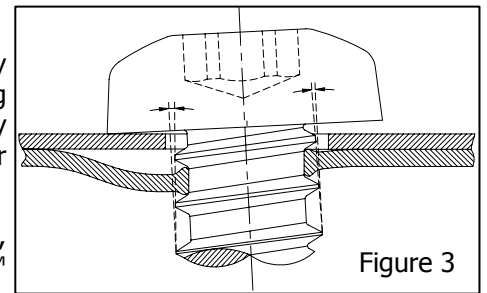

Figure 3

FASTITE® 2000™ thread forming screws were developed to create strong mechanical joints into untapped thin sheets, while providing the "in-place cost savings" long associated with the TAPTITE® range of thread rolling screws.

FASTITE® 2000™ screws are very different from other proprietary screws designed for use in sheet metal. FASTITE® 2000™ screws have standard machine screw pitches, in both inch and metric sizes. A double lead is used and the body has a unique subtle TRILOBULAR™ shape. FASTITE® 2000™ screws have several features, which combine to provide improved performance in sheet metal. *(Cont. on Page 3)*

REMINC STAFF

- Laurie Mandly - Chairman & CEO
- Ralph Barton - President
- Ken Gomes - Vice President
Marketing & Engineering
- Tim Egan - Vice President - Operations
- John Reynolds - Manager - Fastener Engineering
- Don Fosmoen - Manager - Mfg. Engineering
- Suzanne Lilly - Admin. - Intellectual Properties
- Beth Rondeau - Dir. of Financial Administration
- Marena Boyadjian - Administrative Assistant

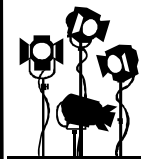

SPOTLIGHT ON Masato Nakano



Masato Nakano is a Market Development Engineer at CONTI Japan. Mr. Nakano graduated from Omori Technical School in Tokyo. He has over 30 years experience in the industrial machine engineering, machine technology and automotive industries. During his extensive career, he gained international experience through multi-year assignments in both France and Germany. Prior to joining CONTI in 2006, he worked as a manager for a major Japanese automotive tier supplier for over 15 years. His major assignments for CONTI include licensee marketing and application engineering support, end-user education in TRILOBULAR™ technology and overall market development for the Japanese market.

R E G I S T E R

President's Perspective

Meeting the Challenges of Globalization



REMINC/CONTI have implemented initiatives on several fronts to meet the numerous challenges of industrial globalization. Globalization is no longer a strategy but a reality which we all need to deal with. Numerous manufacturers, served by our licensees, have migrated to low-cost countries and the suppliers to these companies have also relocated to meet local sourcing requirements. REMINC/CONTI have witnessed at least a dozen of our licensees start new manufacturing operations in Asia. In response, we have taken the necessary steps to assure end-user assemblers that they can obtain competitive local sourcing of licensed products. We have carefully and selectively expanded the size and scope of our licensing program to meet this need, yet at the same time we are watchful not to dilute our strong presence in North America and Europe.

We have licensed only a few of those fastener and tooling manufacturers that can provide quality products made to our specifications and have respect for our Patents, Trademarks and Confidential Technical Information. Most of these licensed companies are extensions of existing licensees in North America, Europe and Asia. We will only work with companies we know and trust, those that will provide licensed products made to the highest standards.

REMINC/CONTI have recently made a substantial investment in Asia in order to protect the Asian market for our licensed products. In addition, we want to expand the applications for licensed products and enhance the value of the licensing program. Yuki Mori and Masi Nakano, located in Tokyo, Japan and Lei Ji Su, located in Shanghai, China, are REMINC/CONTI associates and valuable resources for licensed manufacturers in the Pacific Rim countries. These associates will help us meet the obvious challenges of culture, language, local business customs and the protection of our intellectual properties. REMINC/CONTI are committed to maintaining their presence in Asia in order to provide manufacturing and technical support, education, training and marketing assistance for licensed manufacturers. We believe that this initiative will be welcomed by our Asian Licensees as they develop new applications for our technology in this huge market sector. We encourage our licensees located in this region to contact our local associates for assistance.

The fastener industry has become global in a very short period of time. As you can see, REMINC/CONTI are taking actions and making efforts to meet the challenges of globalization in order to stay ahead of the curve. As the collective Pan-Asian economies have already become the driving force in our global economy, REMINC/CONTI will make every effort to assist licensees and work with end users of our licensed products located in the Pacific Rim region to obtain an increasing share of this market's growth and success.

REMINC Responds! Fielding the Questions

- Q. Can my customer eliminate costly Teflon[®] coatings and masking operations for pilot holes if they use TAPTITE[®] fasteners?
- A. Yes, these Teflon[®] coatings and masking operations on the assembly line are used to eliminate the problem of nuts clogging with clear coat paint, underbody primers, powdered coatings and weld splatter, among other things. TAPTITE[®] fasteners are unaffected by these contaminants and will form quality threads in your customer's application even when the nut is clogged and/or contaminated. The reason for this is that TAPTITE[®] fasteners are thread forming fasteners. As the threads are formed, any contaminants will be literally pushed out of the joint. The fact that TAPTITE[®] fasteners remove this contamination from the joint is one reason why many customers use TAPTITE[®] fasteners in electrical grounding applications.
- Q. Can TAPTITE[®] fasteners be made with the various head and recess styles of machine screws?
- A. Absolutely, any head or recess style that can be made with a machine screw body can be made on a TRILOBULAR[™] body. Our authorized manufacturers have added TRILOBULAR[™] bodies to simple hex flange head fasteners, double ended studs, ball studs, internal and external TORX[®] drives, etc. With today's manufacturing capabilities, the possibilities are almost limitless.
- Q. What about reusing a TAPTITE[®] fastener? Are there any cross threading or re-tapping problems?
- A. No, the TAPTITE[®] fastener will always follow the path of least resistance in a tapped hole eliminating the need for hand-starting or any anti-cross threading features. TAPTITE[®] fasteners, unlike most other locking devices, will also retain some level of prevailing torque, which creates resistance to vibrational loosening even after multiple removals and installations.

A New Approach to Fastening Thin Sheet Metal Panels by Ken Gomes (cont. from Page 1)

FASTITE® 2000™ performance features (See Figure 4).

1. A tapered root adjacent to the screw head to maintain the thread major diameter close to the screw head.
2. An undercut feature to increase the assembly failure torque.
3. A Radius Profile™ thread design combined with a twin lead helix angle to provide a mating thread system whereby diametrically opposed threads are engaged.
4. A non-cut-off "CA" style point for extruding in relatively small pilot holes.

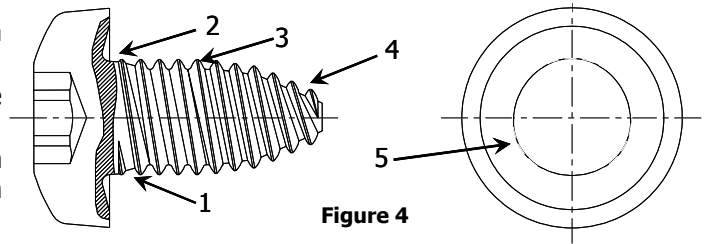

Figure 4

5. A unique TRILOBULAR™ shaped thread body to provide "resistance to loosening".

The double lead helix creates two thread starts, 180° opposite each other. The twin helix provides starting stability by contacting the hole on two sides. Single helix screws, with spaced threads or machine screw threads have starting instability causing the screw to cock. (See Figure 5)

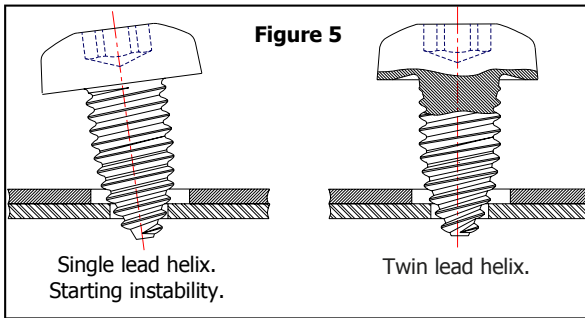

Figure 5

For FASTITE® 2000™ screws, a blunt end "CA" style point is used rather than the more common sharp "needle" point. The small diameter of the blunt "CA" point allows the screw to enter relatively small holes, creating a situation where there is more nut material than can fill the screw body threads. The FASTITE® 2000™ screw, due to the unique TRILOBULAR™ shape, extrudes material towards the screw head (backward extrusion) and screw point (forward extrusion) increasing the amount of engagement to more than the original base thickness of the nut material.

Figure 6 shows a graphical representation of how FASTITE® 2000™ screws extrude the material. Also shown is another feature of the double lead design - the diametrically opposed thread engagement resulting in improved stripping resistance from the screw threads.

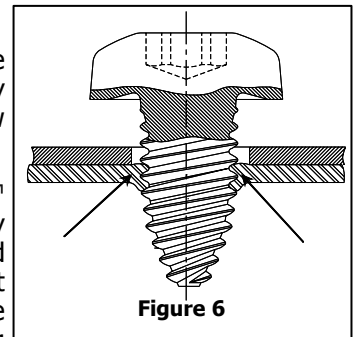

Figure 6

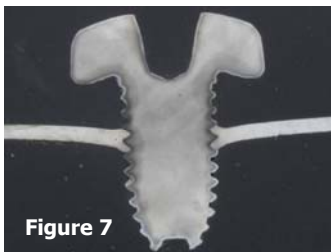

Figure 7

Figure 7 shows an actual cross section of a FASTITE® 2000™ screw driven into sheet steel, which shows the diametrically opposed threads engaged in the sheet and the forward and backward extrusion of the sheet material. Notice the undercut section below the screw head. This feature also increases the stripping resistance provided by the screw head bearing surface. The diametrically opposed threads ensure that the head will seat parallel against the sheet material.

The increased core diameter caused by the thread root rising under the head results in additional forward and backward material extrusion, which provides increased thread engagement and enhanced stripping resistance. See Figures 8 and 9.

FASTITE® 2000™ screws can also be supplied with underhead serrations. If the serrations rubbing against the sheet laminate being fastened are not a concern, underhead serrations will further increase the joint's stripping resistance.

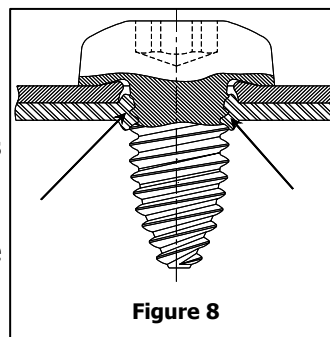

Figure 8

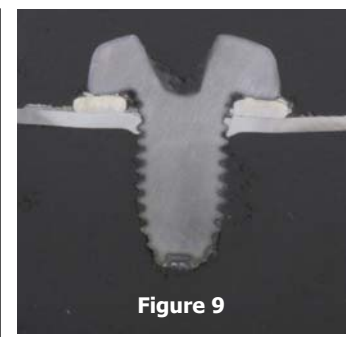

Figure 9

The undercut, which is an integral part of the FASTITE® 2000™ design, makes FASTITE® 2000™ screws an ideal choice for securing grounding connections. In combination with the TRILOBULAR™ shape, the undercut also significantly increases resistance to vibrational loosening.

As an example of the benefits described, M6 size FASTITE® 2000™ screws are used in a new North American vehicle model to attach the inner wheel-well to the fender rail. The steel sheet metal thickness on the older model was 1.5mm thick. On the newer model, the thickness was reduced to 1mm thick - a 33% reduction! The strip failure torque of the original fastener was not to a sufficient level to allow its use. By replacing the original sheet metal fasteners in this fender rail application with M6 FASTITE® 2000™ screws in the 1mm thick steel sheet resulted in an average strip failure torque of 18Nm compared to 8.7Nm - an improvement of 107 %!

Contact our application engineers at REMINC and learn how FASTITE® 2000™ fasteners can be used in your thin sheet metal applications to improve your joint assembly and reduce your "in-place cost of assembly".

REMINC Training / Brochure Request Form

Name: _____

Company: _____

Address: _____

Telephone: _____

Fax: _____

E-mail: _____

Please Check:

- Contact me regarding a training visit
- REMINC General Products Catalog
- TAPTITE 2000® Products Application Guide
- TAPTITE 2000® Product Brochure
- REMFORM® Product Brochure
- TRU-START® Product Brochure
- FASTITE® 2000™ Product Brochure
- "54 Ways TAPTITE 2000® Fasteners Lower the Cost of Assembly" Request Form
- Receive Newsletter by e-mail

Mail this form to REMINC at 55 Hammarlund Way, Tech II, Middletown, RI 02842 USA or fax it to (401) 841-5008

The following are patented products and/or trademarks licensed by REMINC:
TAPTITE®, TAPTITE II®, TYPE-TT®, DUO-TAPTITE®, CORFLEX®, PLASTITE®, POWERLOK®, TRILOBULAR™,
KLEERTITE®, REMFORM®, THE CONTROLLABLE PRODUCT®, ENGINEERED FASTENINGS®, EXTRUDE-TITE®,
KLEERLOK®, TAPTITE 2000®, FASTITE® 2000™, TAPTITE 2K®, TYPE TT 2000®,
TYPE TT 2K®, TAPTITE 2000 & DESIGN®

COPYRIGHT 2007, RESEARCH ENGINEERING & MANUFACTURING INC.
ALL RIGHTS RESERVED

No part or contents of this newsletter may be reproduced without the expressed written consent of
Research Engineering & Manufacturing Inc.



Research Engineering &
Manufacturing Inc.

55 Hammarlund Way, Tech II
Middletown, RI 02842, U.S.A.

Tel: (401) 841-8880

Fax: (401) 841-5008

E-mail: reminc@reminc.net

*For more information on our
products, visit us at taptite.com*

1958 - 2007

**Celebrating 49 Years Lowering
the Cost of Assembly**

